



Smart Rack Controller[®]

Thank you for purchasing Raritan's Smart Rack Controller (SRC). This product provides an ideal rack management solution which features the following functions for data centers and server rooms:

- Support for DX and DX2 environmental sensors, such as temperature and humidity sensors
- Control and detection of a cabinet's door status (optional)
- Asset management, which lists all IT devices

Important: Asset management feature and door handles (or SmartLock kit) are mutually exclusive. You cannot have both devices connected simultaneously.

This Quick Setup Guide explains how to install and configure the SRC. For further details on using the SRC, access online help from the application, or download the user guide from Raritan's **Support page** (<http://www.raritan.com/support/>). For more detailed information on this release, see the latest release notes on the Support page.

Package Contents

The following lists the equipment shipped with SRC. If anything is missing or damaged, contact the local dealer or Raritan Technical Support for help.

- One SRC device
- Bracket pack and screws
- Quick Setup Guide

Optional Accessories

Part or all of the following equipment is shipped on demand only.

- Asset management strips and asset tags
- Door handles or SmartLock kit
- DX and/or DX2 environmental sensor package(s)
- DPX3-ENVHUB4 sensor hubs

Warning: SRC does NOT support these other Raritan environmental sensor packages: DPX, DPX2, DPX3 (except for the DPX3-ENVHUB4 sensor hub).

Before You Begin

Prepare the installation site. Make sure the installation area is clean and not exposed to extreme temperatures or humidity. Allow sufficient space around the SRC for cabling and equipment connections.

Rackmount

There are two ways to mount an SRC device, using the same Raritan rackmount brackets.

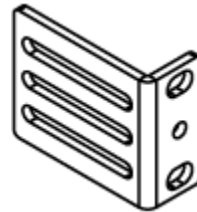

- **1U Rackmount Method** (on page 1)
The SRC is mounted like a 1U device in the rack.
- **0U Rackmount Method** (on page 2)
The SRC is mounted like a 0U device in the rack.

1U Rackmount Method



► To mount SRC like a 1U device:

1. Align the two edge slots of the L-bracket with two of the screw holes on one end of the SRC device.

2. Screw the L-bracket to the device and ensure the bracket is fastened securely.

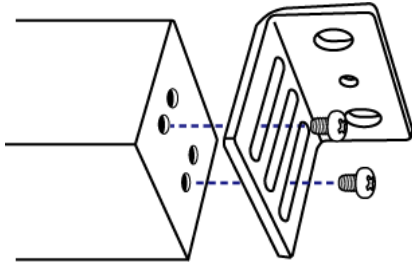

3. Repeat Steps 1 to 2 to screw another L-bracket to the other end of the device.
4. After both L-brackets are installed, fasten the device to the rack, using rack screws, through two identical round holes of each L-bracket.

OU Rackmount Method

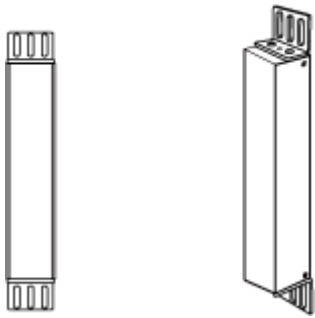

► To mount SRC like a OU device:

1. Align the two round holes of the L-bracket with two of the screw holes on the top of the SRC device.
2. Screw the L-bracket to the device and ensure the bracket is fastened securely.

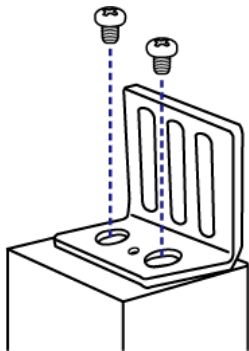

3. Repeat Steps 1 to 2 to screw another L-bracket to the other end of the device.
4. After both L-brackets are installed, fasten the device to the rack, using rack screws, through slots of each L-bracket.

Connection Ports for Sensors, Door Handles, and Assets

If you purchase **Optional Accessories** (on page 1), make sure you connect them to the correct port on the SRC. Connecting to the wrong port may cause damage to SRC and/or connected accessories.

Door Handle Ports (Optional)

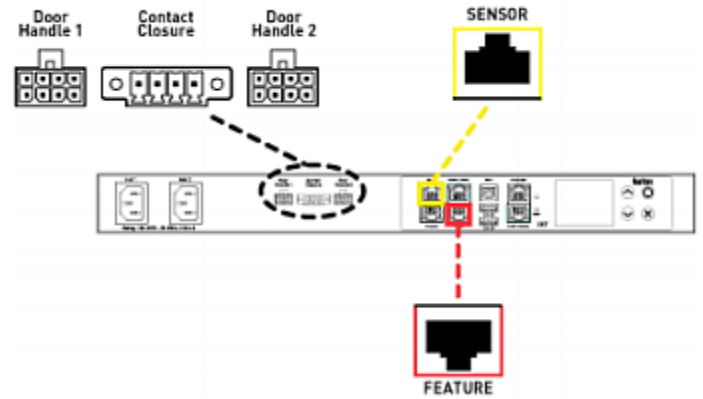

| SRC models | Connection ports | Supported accessories |
|---|--|--|
| All models | SENSOR port (yellow) | <ul style="list-style-type: none"> Raritan's DX or DX2 sensors or actuators SmartLock kit (that is, DX2-DH2C2) Refer to "FEATURE 1" below. |
| Models with onboard door handle ports. SRC-0102 | Door handle ports, and contact closure terminals | <ul style="list-style-type: none"> Raritan's door handles Third-party contact closure detectors (optional) Refer to "FEATURE 2" below. |
| All models | FEATURE port (red) | <ul style="list-style-type: none"> Raritan's asset management strips Refer to "FEATURE 3" below. |

FEATURE 1: Support for DX and DX2 Environmental Sensors/Actuators

Raritan's **DX** or **DX2** environmental sensor packages are required for SRC to detect the surrounding condition like the temperature, or to control a system like door handles.

Connecting Environmental Sensors (Optional)

SRC provides the SENSOR port for connecting Raritan DX or DX2 environmental sensor packages so that you can remotely monitor environmental factors, such as temperature and humidity, around the rack.

- For sensor connection instructions, refer to the SRC User Guide or Online Help.
- For detailed information on each sensor package, refer to the Environmental Sensors and Actuators Guide (or Online Help) on Raritan website's **Support page** (<http://www.raritan.com/support/>).

FEATURE 2: Cabinet Access Control

Raritan's door handles or SmartLock kits are required for SRC to control the access to a cabinet.

Depending on your SRC model, you may have to purchase either only door handles or a full SmartLock kit from Raritan.

Raritan's SmartLock kit contains one DX2-DH2C2 and a pair of door handles.

Note: For details, refer to the user documentation accompanying the SmartLock kit or download it from Raritan's **Support page** (<http://www.raritan.com/support/>).

To detect the cabinet's door status, you need to connect third-party contact closure detectors, which are optional.

Important: It is not guaranteed that all third-party detectors/switches are compatible with the SRC. You need to test the compatibility after installing them.

Limitations

Read the restrictions below before connecting door handles or a SmartLock kit (that is, DX2-DH2C2 kit) to SRC.

- Up to one DX2-DH2C2 can be connected per SENSOR port of SRC.
 - SRC-0100 supports a maximum of 2 door handles by connecting one DX2-DH2C2.
 - SRC-0102 has two onboard door handle ports so it supports a maximum of 4 door handles. You can connect two door handles to onboard door handle ports and connect one DX2-DH2C2 to its SENSOR port.
- Only the door handles sold with DX2-DH2C2 are supported.
- No hot plugging or hot swapping with door handles when they are directly or indirectly connected to a *powered* SRC.
 - That is, no connection or disconnection of door handles when they are powered.
- The maximum cabling length for door handles or SmartLock kit is 29 feet (9 meters). For details, refer to the following diagram.

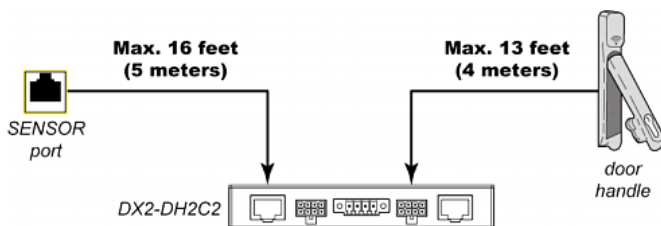

Connecting a SmartLock Kit to DX2-DH2C2

You need a SmartLock kit if your SRC does NOT include a built-in DX2-DH2C2, such as SRC-0100.

- ▶ **DX2-DH2C2 ports and terminals:**

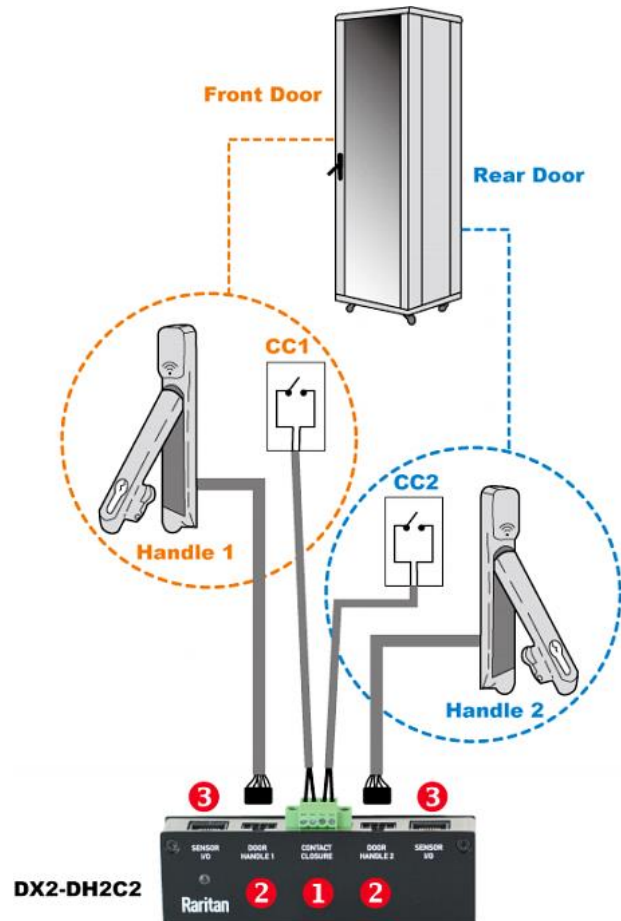

| No. | Component | Function |
|-----|---|---|
| 1 | Two pairs of contact closure sensor terminals | Connect to third-party contact closure detectors/switches for detecting the door open/closed status. Contact closure detectors are OPTIONAL. |
| 2 | Two door handle ports | Connect to the standard category cable of the door handle. The two door handles are usually attached to different doors of the same cabinet. |

| No. | Component | Function |
|-----|-----------------|--|
| 3 | Two RJ-45 ports | <p>Connect a standard network patch cable for either or both purposes below:</p> <ul style="list-style-type: none"> Connect to the SENSOR port (yellow) of the SRC. Cascade DX2 sensor package(s). <p>Exception: You CANNOT cascade DX2-DH2C2 packages.</p> |

► **Connection procedure:**

1. Connect supported door handles to DX2-DH2C2.
2. (Optional) Connect contact closure detectors/switches for detecting door status to DX2-DH2C2. For connection details, refer to the Environmental Sensors and Actuators Guide on the **Support page** (<http://www.raritan.com/support/>).
3. Connect DX2-DH2C2 to the SENSOR port of SRC. Always connect DX2-DH2C2 directly to the sensor port. If you are cascading with other sensors, the DX2-DH2C2 must be in the first position, directly connected to the sensor port.

Connecting Raritan's Door Handles to SRC

You only need to purchase door handles if your SRC has a built-in DX2-DH2C2, such as SRC-0102.

► **SRC door handle ports and terminals:**

Numbers in the following diagram (1 and 2) correspond to the numbers in the previous section's table.

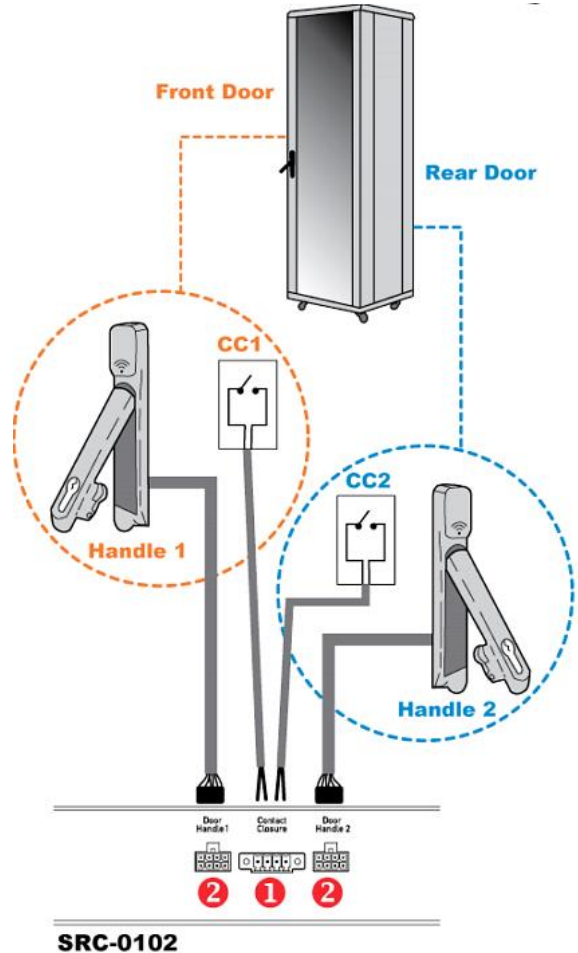

► **Connection procedure:**

1. Connect Raritan door handles to onboard door handle ports of SRC.
2. (Optional) Connect contact closure detectors/switches for detecting door status to contact closure terminals of SRC.

FEATURE 3: Asset Management

Both asset management strips and asset tags are required for SRC's asset management feature.

Limitation: Do NOT connect door handles or SmartLock kit to SRC while asset strips are being connected to SRC.

Introduction to Regular Asset Strips

Each tag port on the regular asset strips corresponds to a rack unit and can be used to locate IT devices in a specific rack (or cabinet).

For each rack, you can attach asset strips up to 64U long, consisting of one MASTER and multiple SLAVE asset strips.

The difference between the master and slave asset strips is that the master asset strip has an RJ-45 connector while the slave does not.

The following diagram illustrates some asset strips. Note that Raritan provides more types of asset strips than the diagram.

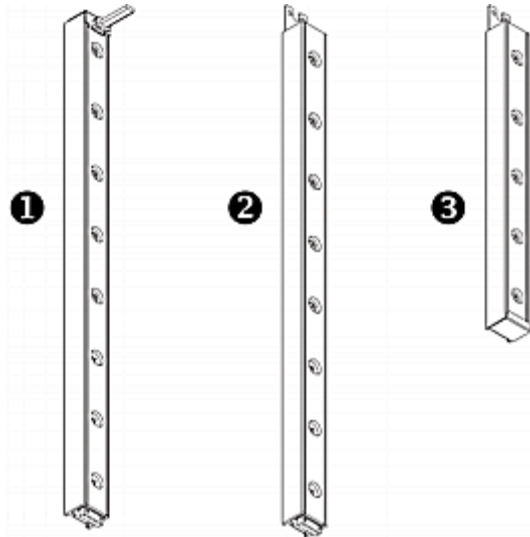

| | |
|----------|--|
| 1 | 8U MASTER asset strip with 8 tag ports |
| 2 | 8U SLAVE asset strip with 8 tag ports |
| 3 | 5U "ending" SLAVE asset strip with 5 tag ports |

Note: Unlike general slave asset strips, which have one DIN connector respectively on either end, the ending slave asset strip has one DIN connector on only one end. An ending asset strip is installed at the end of the asset strip assembly.

Introduction to Asset Tags

You need both asset strips and asset tags for tracking IT devices.

Asset tags provide an ID number for each IT device. The asset tags are adhered to an IT device at one end and plugged in to an asset strip at the other.

The asset strip is connected to the SRC, and the asset tag transmits the ID and positioning information to the asset strip.

The following diagram illustrates an asset tag. Note that there are two types of asset tags: non-programmable and programmable tags. The only difference is that programmable asset tags allow you to customize each tag's ID or barcode number while non-programmable ones have factory default ID or barcode numbers, which you cannot change.



| | |
|----------|---|
| A | Barcode (ID number), which is available on either end of the "non-programmable" asset tag |
| B | Tag connector |
| C | Adhesive area with the tape |

Note: The barcode of each "non-programmable" asset tag is unique and is displayed in the SRC device's web interface for identification.

Assembling Regular Asset Strips

Before connecting regular asset strips to the SRC, you must assemble them.

► To assemble regular asset strips:

1. Connect all regular asset strips up to 64U. For detailed information, refer to the user documentation accompanying Raritan asset strips.

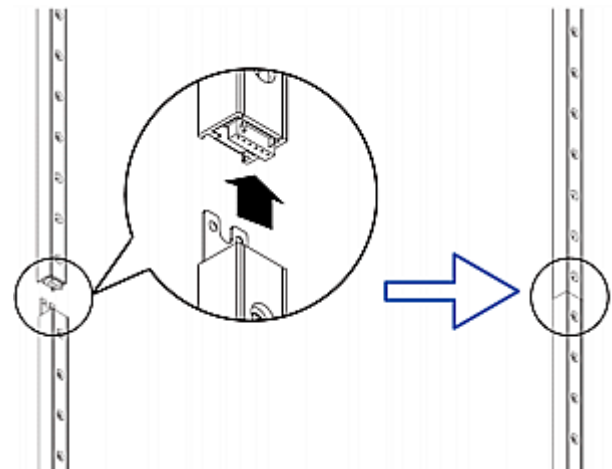

- a. The MASTER asset strip is installed as the first one in the asset strip assembly.
- b. All SLAVE asset strips are connected following the MASTER asset strip.
- c. The "ending" slave asset strip is installed as the final one.

- Vertically attach the asset strip assembly to the rack, next to the IT equipment, making each tag port horizontally align with a rack unit.

The asset strips are automatically attracted to the rack because of magnetic stripes on the back.

Connecting Regular Asset Strips to SRC

SRC supports a cabling distance up to 10 meters for each connected asset strip assembly.

► To connect regular asset strips to SRC:

- Affix the adhesive end of an asset tag to each IT device through the tag's tape.
- Plug the connector of each asset tag into the corresponding tag port on the asset strip.
- Connect the MASTER asset strip's RJ-45 connector to a port labeled **FEATURE** on SRC, using a network patch cable (CAT5e or higher).

| | |
|-----|--------------------|
| (A) | MASTER asset strip |
| (B) | Asset tags |
| (C) | IT devices |

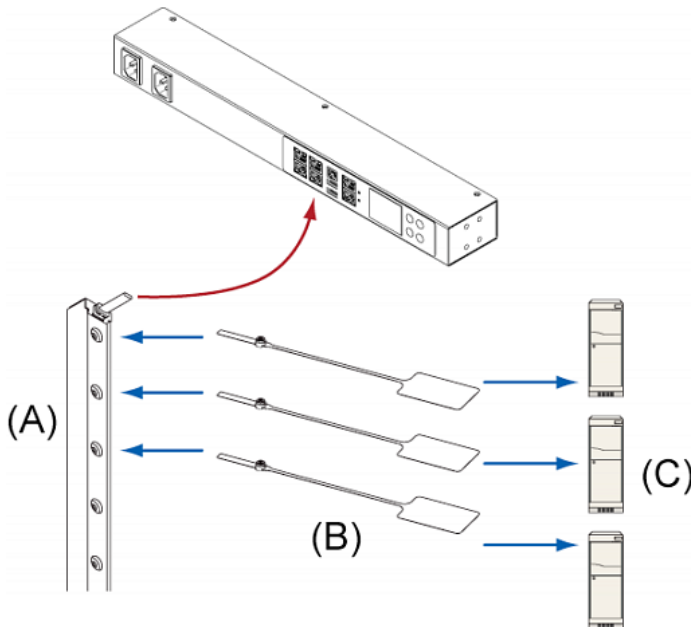

Other Types of Asset Strips

Raritan provides more types of asset strips than regular asset strips, such as composite asset strips or blade extension strips. For detailed information, refer to the user documentation accompanying Raritan asset strips.

► Composite asset strips:

- A composite asset strip is named AMS-Mx-Z, where x is a number, such as AMS-M2-Z or AMS-M3-Z.
- A composite asset strip has two RJ-45 connectors but less tag ports.
- The composite asset strip is especially useful for tracking large devices such as SAN boxes in the cabinet.
- Composite asset strips can be daisy chained as shown below.

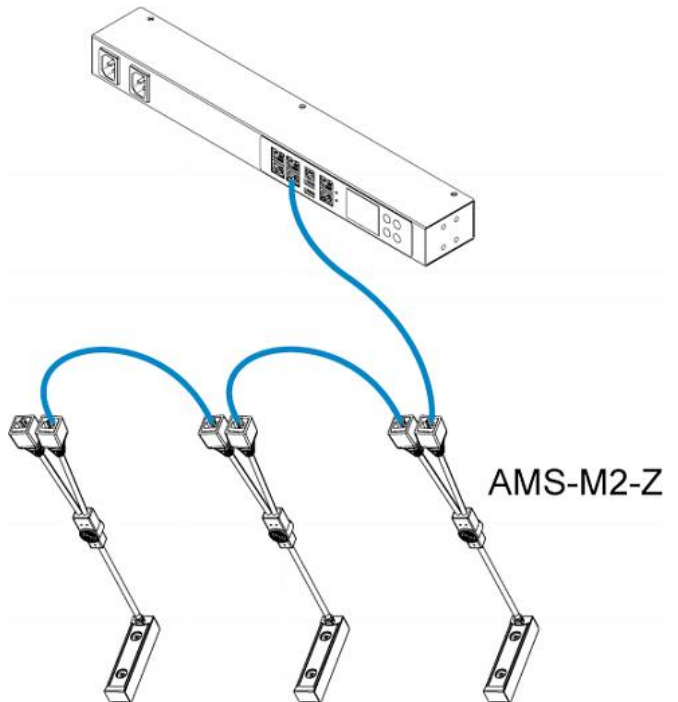

► Blade extension strips:

- For blade servers, which are contained in a single chassis, you can use a blade extension strip to track individual blade servers.
- A blade extension strip contains 4 to 16 tag ports. Below shows a blade extension strip with 16 tag ports.

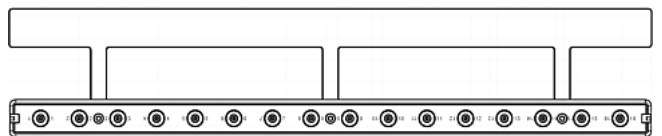

- The blade extension strip is connected to a tag port on a regular or composite asset strip via a Raritan's tag connector cable.

Connecting SRC to Power

SRC supports redundant power with two inlets. See Product Models.

You can connect only one or both inlets to proper power sources.

- Connect each SRC to an appropriately rated branch circuit. Refer to the label or nameplate affixed to your SRC for appropriate input ratings or range of ratings.
- When a SRC powers up, it proceeds with the power-on self test and software loading for a few moments.

- When the software has completed loading, the front panel display illuminates.

Connecting SRC to Your Network

SRC can be connected to a wired or wireless network.

▶ To make a wired connection:

- Connect a standard network patch cable to either or both Ethernet ports on the SRC.
- Connect the other end of the cable to your LAN.

Note: The "green" Ethernet port labeled "ETH①10/100/1000" supports up to 1000 Mbps so it is highly recommended for network connection. If connecting both ports to the LAN, you must connect them to two "different" subnets. If you are not sure whether the device is connected to the same or different subnets, contact your IT department.

▶ To make a wireless connection:

- Connect an appropriate USB wireless LAN adapter to SRC.
- Make sure the wireless LAN configuration is supported by your SRC. See **Appendix B: Wireless LAN Information** (on page 8).

Using a Web Browser

Initial configuration using a web browser involves these two steps.

Step 1: Retrieve the IP Address (on page 7)

Step 2: Log in to the SRC Web Interface (on page 7)

Step 1: Retrieve the IP Address

After connecting to a DHCP IPv4 network, an IPv4 address is automatically assigned to your SRC. You can operate the front panel display to retrieve the IPv4 address. See **Using the Front Panel Display** (on page 7).







Tip: You can also retrieve the IPv4 address by connecting an iOS or Android mobile device to SRC. See **Appendix A: Configuration via a Mobile Device or PDView** (on page 7).

Using the Front Panel Display

The SRC front panel display is similar to the diagram below.



▶ To retrieve the IP address:

- Press  or  to show the "Main Menu."
- Press  or  to select "Device Info," and press .
- Press  or  until the device's IP address is displayed.

Step 2: Log in to the SRC Web Interface

The SRC supports common web browsers, including Microsoft Internet Explorer®, Mozilla Firefox®, and Google® Chrome.

▶ To access the SRC web interface:

- Open a web browser and type the IP address of SRC.

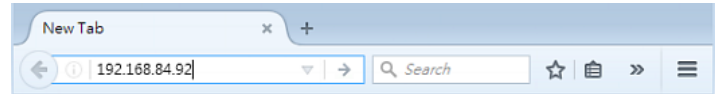

- Accept any security warnings that may appear.
- Type the default user credentials and click Login.
 - User name: admin
 - Password: raritan
- When prompted to change the password, change or ignore it.
 - To change it, type the new password and click Ok.
 - To ignore it for this time only, click Not Now.
 - To ignore it permanently, select "Do not ask again" and click Not Now.

It is highly recommended to change the default password.

Make sure the new password is noted down and kept in a secure place.

Step 3: Configure SRC

After logging in to the SRC web interface, you can navigate the left menu and then:

- Choose Asset Strips for configuring connected asset strips.
- Choose Peripherals for configuring connected environmental sensor packages.
- Choose SmartLock for configuring connected door handles or SmartLock kit.
- Choose Device Settings > Date/Time to configure the SRC with the proper date and time or synchronize it with an NTP server. The SRC device's time must be in sync with the LDAP server to use LDAP authentication.
- Choose other menu commands for configuring user profiles, privileges, securities, and more.

Note: Detailed instructions are available in the SRC online help or user guide.

Appendix A: Configuration via a Mobile Device or PDView

An iOS or Android mobile device, such as a smartphone or tablet, can function as a local display of SRC. Note that the Android device must support USB "On-The-Go" (OTG), or this function does not work.

Step 1: Download the "PDView" App

Raritan's app "PDView" is required for the mobile device to function as a local display. It is a free app.

► **To download PDView:**

1. Visit either Apple App or Google Play Store.
 - <https://itunes.apple.com/app/raritan-pdview/id780382738>



- <https://play.google.com/store/apps/details?id=com.raritan.android.pdview>



2. Install PDView.



Step 2: Connect the Mobile Device to SRC

The USB cable and USB port to connect are determined by your mobile operating system.

► **To connect your mobile device to SRC:**

1. Get an appropriate USB cable for your mobile device.
 - *iOS:* Use the regular USB cable shipped with your iOS mobile device.
 - *Android:* Use an **USB OTG** adapter cable.
2. Connect the mobile device to the appropriate USB port on the SRC.
 - *iOS:* USB-A port.
 - *Android:* USB-B port

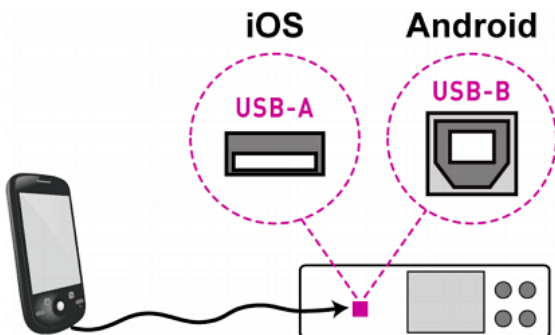

Step 3: Launch PDView

You can access the SRC web interface via PDView to view or change the settings.

► **To access the SRC web interface:**

1. Launch PDView on your mobile device.

2. Wait until PDView detects the connected SRC and shows the word "Connected" in green.

Connected

3. If the factory-default user credentials "admin/raritan" remain unchanged, PDView automatically logs in to the web interface of SRC.
 - If they have been changed, the login screen displays instead and you must enter appropriate user credentials for login.
4. (Optional) For initial login, you are prompted to change the password. See **Step 2: Log in to the SRC Web Interface** (on page 7).
5. Now you can view the data or change any SRC settings.
 - For details, refer to the user guide or online help on the Raritan website.

Appendix B: Wireless LAN Information

USB Wireless LAN Adapters

The SRC supports the following USB Wi-Fi LAN adapters.

| Wi-Fi LAN adapters | Supported 802.11 protocols |
|-----------------------|----------------------------|
| SparkLAN WUBR-508N | A/B/G/N |
| Proxim Orinoco 8494 | A/B/G |
| Zyxel NWD271N | B/G |
| Edimax EW-7722UnD | A/B/G/N |
| TP-Link TL-WDN3200 v1 | A/B/G/N |
| Raritan USB WIFI | A/B/G/N |

Connecting the Wireless LAN Adapter

You can connect the wireless LAN adapter either to SRC or to a USB hub attached to SRC.

► **To make a wireless connection:**

- Do one of the following:
- Plug a supported USB wireless LAN adapter into the USB-A port on your SRC.
 - Connect a USB hub to the USB-A port on the SRC. Then plug the supported USB wireless LAN adapter into the appropriate USB port on the hub.

Supported Wireless LAN Configuration

If wireless networking is preferred, ensure that the wireless LAN configuration of your SRC matches the access point. The following is the wireless LAN configuration that the SRC supports.

- Network type: 802.11 A/B/G/N
- Protocol: WPA2 (RSN)

- Key management: WPA-PSK, or WPA-EAP with PEAP and MSCHAPv2 authentication
- Encryption: CCMP (AES)

Tip: Supported 802.11 network protocols vary according to the wireless LAN adapter being used with the SRC. See *USB Wireless LAN Adapters* (on page 8).

Note: You must configure SRC to enable its wireless LAN interface. See the topic titled *Configuring Network Settings in the Administrators Guide*.

Appendix C: More Information

Additional Information

For more information about SRC and the entire Raritan product line, see Raritan's website (www.raritan.com). For technical issues, contact Raritan Technical Support. See the Contact Support page in the Support section on Raritan's website for technical support contact information worldwide.

Raritan's products use code licensed under the GPL and LGPL. You can request a copy of the open source code. For details, see the Open Source Software Statement at (<http://www.raritan.com/about/legal-statements/open-source-software-statement/>) on Raritan's website.

RJ-45 Cap in the EXPANSION Port

SRC has a cap plugged into its EXPANSION port when shipping out of the factory. This port is reserved for future use and does NOT function. It is suggested to keep the cap plugged continuously.

