



Server Technology

Solutions for the Data Center Equipment Cabinet

Sentry

Commander

- PT46

Installation Manual

**Instructions**

This symbol is intended to alert the user to the presence of important operating and maintenance (servicing) instructions in the literature accompanying the appliance.

**Dangerous Voltage**

This symbol is intended to alert the user to the presence of un-insulated dangerous voltage within the product's enclosure that may be of sufficient magnitude to constitute a risk of electric shock to persons.

**Protective Grounding Terminal**

This symbol indicates a terminal that must be connected to earth ground prior to making any other connections to the equipment.

Life-Support Policy

As a general policy, Server Technology does not recommend the use of any of its products in the following situations:

- life-support applications where failure or malfunction of the Server Technology product can be reasonably expected to cause failure of the life-support device or to significantly affect its safety or effectiveness.
- direct patient care.

Server Technology will not knowingly sell its products for use in such applications unless it receives in writing assurances satisfactory to Server Technology that:

- the risks of injury or damage have been minimized,
- the customer assumes all such risks, and
- the liability of Server Technology is adequately protected under the circumstances.

The term life-support device includes but is not limited to neonatal oxygen analyzers, nerve stimulators (whether used for anesthesia, pain relief or other purposes), auto-transfusion devices, blood pumps, defibrillators, arrhythmia detectors and alarms, pacemakers, hemodialysis systems, peritoneal dialysis systems, neonatal ventilator incubators, ventilators (for adults or infants), anesthesia ventilators, infusion pumps, and any other devices designated as "critical" by the U.S. FDA.

**Please Recycle**

Shipping materials are recyclable. Please save them for later use, or dispose of them appropriately.

Notices

Copyright © 2004-2005 Server Technology, Inc. All rights reserved.
1040 Sandhill Drive
Reno, Nevada 89521 USA

All Rights Reserved

This publication is protected by copyright and all rights are reserved. No part of it may be reproduced or transmitted by any means or in any form, without prior consent in writing from Server Technology.

The information in this document has been carefully checked and is believed to be accurate. However, changes are made periodically. These changes are incorporated in newer publication editions. Server Technology may improve and/or change products described in this publication at any time. Due to continuing system improvements, Server Technology is not responsible for inaccurate information which may appear in this manual. For the latest product updates, consult the Server Technology web site at www.servertech.com. In no event will Server Technology be liable for direct, indirect, special, exemplary, incidental or consequential damages resulting from any defect or omission in this document, even if advised of the possibility of such damages.

In the interest of continued product development, Server Technology reserves the right to make improvements in this document and the products it describes at any time, without notices or obligation.

Table of Contents

CHAPTER 1: INTRODUCTION	2
Quick Start Guide.....	2
Technical Support	2
Equipment Overview.....	2
CHAPTER 2: INSTALLATION	3
Standard Accessories.....	3
Additional Required Items	3
Safety Precautions	3
Mounting	3
Connecting to the Power Source	3
Connecting to the Power Tower XL.....	4
Connecting Devices.....	4
Configuring and Operating the PT46 Commander.....	4
CHAPTER 3: APPENDICES	5
Appendix A: Technical Specifications	5
Appendix B: Intelligent Power Modules	7
Appendix C: Warranty, Product Registration and Support	8

Chapter 1: Introduction

Quick Start Guide

The following instructions will help you quickly install and configure your Commander for use on your network. For detailed information on each step, go to the page number listed to the right.

1. Mount the Commander.....3
2. Connect to the power source3
3. Connect to the Power Tower XL.....4
4. Connect the devices to the Commander4
5. Configure the Commander4

Technical Support

Server Technology understands that there are often questions when installing and/or using a new product. Free Technical Support is provided from 8:30 AM to 5:00 PM, Monday-Friday, Pacific Time.

Server Technology, Inc.

1040 Sandhill Drive

Reno, Nevada 89521 USA

Tel: 775.284.2000

Fax: 775.284.2065

Web: www.servertech.com

Email: support@servertech.com

Equipment Overview

1. The power inlet connects the Commander to the electrical power source.
2. RJ12 Intelligent Power Module ports.
3. One RJ12 Link connector for connection to a Power Tower XL.

A number is printed next to the Intelligent Power Module ports. These numbers may be used in commands that require a name.

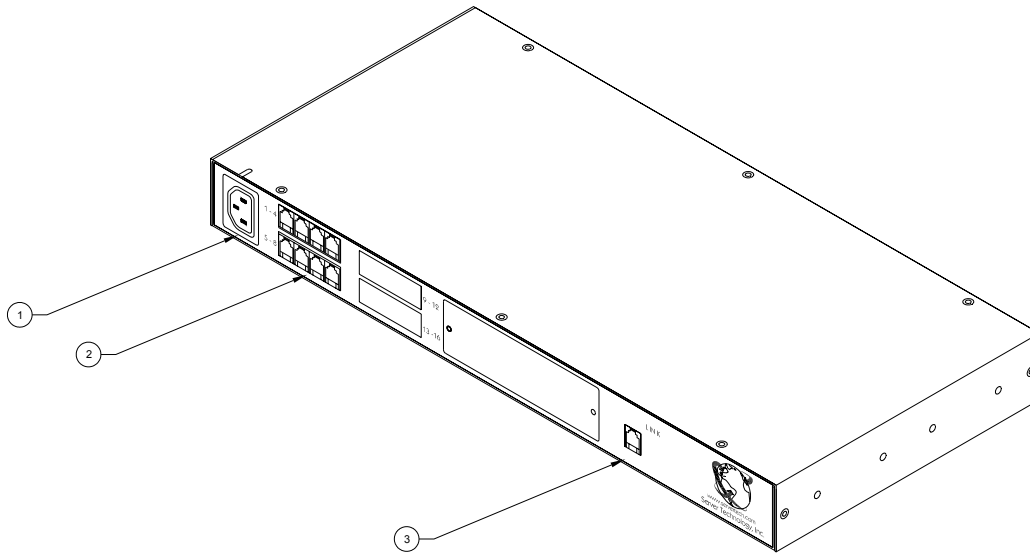

Figure 1.1 Sentry PT46 Commander

Chapter 2: Installation

Before installing your Commander, refer to the following lists to ensure that you have all the items shipped with the unit as well as all other items required for proper installation.

Standard Accessories



- Mounting bracket hardware: two mounting brackets and four screws
- RJ12 to RJ12 crossover cable
- Input power cord retention clip
- Separate power input cord

Additional Required Items

- Phillip screwdriver
- Screws, washers and nuts to attach the Commander to your rack

Safety Precautions

This section contains important safety and regulatory information that should be reviewed before installing and using the Commander. For input and output current ratings, see *Power Ratings* on page 5.

	Only for installation and use in a Service Access Location in accordance with the following installation and use instructions.	<i>Destiné à l'installation et l'utilisation dans le cadre de Service Access Location selon les instructions d'installation et d'utilisation.</i>	Nur für Installation und Gebrauch an Anschlusszugriffspunkten gemäß der folgenden Installations- und Gebrauchsanweisungen.
	The plug on the power supply cord shall be installed near the equipment and shall be easily accessible.	<i>La prise sur le cordon d'alimentation sera installée près de l'équipement et sera facilement disponible.</i>	Der Stecker des Netzkabels muss in der Nähe der Ausrüstung installiert werden und leicht zugänglich sein.
	Always disconnect the power supply cord before opening to avoid electrical shock.	<i>Toujours déconnecter le cordon d'alimentation avant d'ouvrir pour éviter un choc électrique.</i>	Ziehen Sie vor dem Öffnen immer das Netzkabel heraus, um die Gefahr eines elektrischen Schlags zu vermeiden.
	WARNING! High leakage current! Earth connection is essential before connecting supply!	ATTENTION ! <i>Haut fuite très possible ! Une connexion de masse est essentielle avant de connecter l'alimentation !</i>	ACHTUNG! Hoher Verluststrom! Ein Erdungsanschluss ist vor dem Einschalten der Stromzufuhr erforderlich!

Mounting

4. Select the appropriate bracket mounting points for proper mounting depth within the rack.
5. Attach the brackets to these mounting points with two screws for each bracket.
6. Install the enclosure into your rack, using the slots in each bracket. The slots allow about ¼ inch of horizontal adaptability to align with the mounting holes of your rack.

NOTE: A mounting bracket kit for 23" wide racks or cabinets is available. Contact your Server Technology Sales Representative for more information.

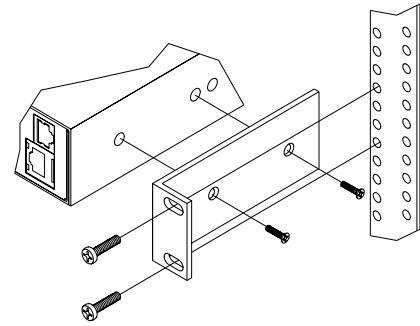

Figure 2.1 Mounting

Connecting to the Power Source

The input power cord must first be attached to the unit before connecting the unit to the power source.

To attach the power cord to the unit:

Install the retention clip; Pull the prongs out slightly and insert them into holes on the Commander, then insert the device's power cord and snap the clip over the cord.

To connect to the power source:

Plug the male end of the power cord into the AC power source.

Connecting to the Power Tower XL

Connect the PT46 Commander to the Power Tower XL with the provided RJ12 crossover cable at the Link port on the PTXL.

NOTE: The overall length of the RJ11 crossover cable should not exceed 10 feet.

Connecting Devices

To avoid the possibility of noise due to arcing, keep the device's on/off switch in the off position until after it is plugged into the outlet, or log in to the Commander and turn the Intelligent Power Module ports off before connection is made. After connecting the Intelligent Power Module (IPM), turn them on using the Commander. See Intelligent Power Modules on page 7 for more information on available Intelligent Power Modules.

1. Connect the Intelligent Power Module(s) to the Commander using the RJ12 crossover cable(s) supplied with the IPM.
2. Connect IPMs to the outlets.
For IPMs with retention clips
IPMx-R-x: Insert the power cord and snap the clip over the cord.
PM20-x-x: Insert the power cord and tighten the two screws on the retention bracket
3. Connect devices to the Intelligent Power Modules.
For IPMs with retention clips
IPMx-x-x: Insert the device's power cord and snap the clip over the cord.
PM20-x-x: Insert the device's power cord and tighten the two screws on the retention bracket

Configuring and Operating the PT46 Commander

All configuration and operation of the PT46 Commander is performed and controlled through the standard Power Tower XL interface and command structure. See the *Power Tower XL Installation and Operations Manual* for specific configuration and operational requirements and commands.

Chapter 3: Appendices

Appendix A: Technical Specifications

Models

Model	Voltage	Inlet*	IPM Ports
PT46-H008-0-07	100-120V or 208-240V, 50/60Hz	IEC 60320/C14	8

* Standard supplied power input cords (Contact your account representative for other options):

1. IEC 60320/C13 to NEMA L5-15P for 100-120V units.
2. IEC 60320/C13 to IEC60320/C14 for 208-240V units.

Power Ratings

Model <i>Modele</i> Modell	Input Current Ratings ₁ <i>L'indice du courant d'entrée</i> Eingangsstromstärke		Output Current Ratings <i>L'indice du courant de sortie</i> Ausgangsstromstärke			Total <i>Total</i> Insgesamt
	Voltage <i>Tension</i> Spannung	Current <i>Courant</i> Strom	Voltage <i>Tension</i> Spannung	Outlet <i>Prise</i> Anschlussstelle		
PT46-H0xx-0-07	100-120V 50/60Hz	0.25	n/a	n/a		n/a
	208-240V 60Hz	0.12	n/a	n/a		n/a
	230V 50/60Hz	0.12	n/a	n/a		n/a

¹ All current ratings are in amperes. *Tous les indices de courant sont en ampères.* Alle Angaben der Stromstärke erfolgen in Ampere.

Physical Specifications

	Operating	Storage
Temperature	32° to 122° F (0° to 50° C)	-40° to 185° F (-40° to 85° C)
Elevation (above MSL)	0 to 10,000 ft (0 to 3000m)	0 to 50,000 ft (0 to 15000m)
Relative Humidity	10 to 90%, non-condensing	10 to 90%, non-condensing
	Dimensions (H x W x D)	Weight
PT46-H0xx	1.75 x 17.0 x 7.0 in. (45 x 432 x 178 mm)	8.2 lbs (3.7 kg)

Regulatory Compliance

Product Safety

Units have been safety tested and certified to the following standards:

- USA/Canada UL 60950:2003 and CAN/CSA 22.2 No. 60950-1-03
- European Union EN60950-1:2001

This product is also designed for Norwegian IT power system with phase-to phase voltage 230V.

USA Notification

Note: This equipment has been tested and found to comply with the limits for a Class A digital device, pursuant to part 15 of the FCC Rules. These limits are designed to provide reasonable protection against harmful interference when the equipment is operated in a commercial environment. This equipment generates, uses, and can radiate radio frequency energy and, if not installed and used in accordance with the instruction manual, may cause harmful interference to radio communications. Operation of this equipment in a residential area is likely to cause harmful interference in which case the user will be required to correct the interference at his own expense.

Modifications not expressly approved by the manufacturer could void the user's authority to operated the equipment under FCC rules.

Canadian Notification

This Class A digital apparatus complies meets all requirements of the Canadian Interference-Causing Equipment Regulations.

Cet appareil numérique de la classe A respecte toutes les exigences du Règlement sur le matériel brouilleur du Canada.

European Union Notification

Products with the CE Marking comply with both the EMC Directive (89/336/EEC) and the Low Voltage Directive (73/23/EEC) issued by the Commission of the European Community.

Compliance with these directives implies conformity to the following European Norms:

- EN55022 Electromagnetic Interference
- EN55024 Electromagnetic Immunity
- EN60950-1 Product Safety
- EN61000-3 Harmonics and Flicker

Japanese Notification

この装置は、情報処理装置等電波障害自主規制協議会 (V C C I) の基準に基づくクラスA情報技術装置です。この装置を家庭環境で使用すると電波妨害を引き起こすことがあります。この場合には使用者が適切な対策を講ずるよう要求されることがあります。

Recycling



Server Technology Inc. encourages the recycling of its products. Disposal facilities, environmental conditions and regulations vary across local, state and country jurisdictions, so Server Technology encourages consultation with qualified professional and applicable regulations and authorities within your region to ensure proper disposal.

Waste Electrical and Electronic Equipment (WEEE)



In the European Union, this label indicates that this product should not be disposed of with household waste. It should be deposited at an appropriate facility to enable recovery and recycling.

For information on how to recycle this product responsibly in your country, please visit: www.servertech.com/support/recycling.

Appendix B: Intelligent Power Modules

Sentry PT46 Commanders are able to perform the advanced power management functions by communicating to Intelligent Power Modules (IPMs). IPMs contain all hardware and logic required to control the power output connector on the IPM as well as monitor and report outlet operating states.

PT46 Commanders support up to 8 external IPMs. External IPMs are designed for in-line connection between the power source and the device to be powered and they are controlled by the Commander using a supplied RJ12 crossover cable. External IPMs also feature an LED for IPM power status.

Standard Models

Model	Voltage	Features	Inlet	Outlet
IPM3-0-3	100-120V AC 50/60 Hz	10 Amp	IEC 60320 C14	IEC 60320 C13
IPM3-R-3	100-120V AC 50/60 Hz	10 Amp w/ retainer clips	IEC 60320 C14	IEC 60320 C13
IPM5-0-2	208-240V AC 50/60 Hz	6 Amp	IEC 60320 C14	IEC 60320 C13
IPM5-0-2	208-240V AC 50/60 Hz	6 Amp, w/ retainer clips	IEC 60320 C14	IEC 60320 C13
PM20-0-1	100-120V AC 50/60 Hz	16 Amp, w/ retainer clips	IEC 60320 C14	IEC 60320 C20
PM20-0-2	208-240V AC 50/60 Hz	16 Amp, w/ retainer clips	IEC 60320 C20	IEC 60320 C19
PM48-0-1	-48V DC	20 Amp	Screw down terminal	Screw down terminal

NOTE:

1. IPM rack mounting kits are available. Contact your Server Technology Sales Representative for more information.
2. For more information regarding inlet/outlet specifications, please go to Panel Components at www.panelcomponents.com.

LED Indicators

Intelligent Power Modules are equipped with a status LED. A lit/on LED indicates that power is being supplied at the port and a darkened/off LED indicates that there is no power at the port.

Appendix C: Warranty, Product Registration and Support

Warranty and Limitation of Liability

Server Technology, Inc. agrees to repair or replace Products that fail due to a defect within twelve (12) months after the shipment date of each Product unit to Buyer (“Warranty Period”). For purposes of this Agreement the term “defect” shall mean the Product fails to operate or fails to conform to its applicable specifications. Any claim made pursuant to this Agreement shall be asserted or made in writing only by Buyer. Buyer shall comply with Server Technology’s Standard Return Merchandise Authorization (“RMA”) procedure for all warranty claims as set forth in Server Technology’s operation manual.

Buyer must return Products in original packaging and in good condition. This limited warranty does not include labor, transportation, or other expenses to repair or reinstall warranted Products on site or at Buyer’s premises.

Server Technology reserves the right to investigate any warranty claims to promptly resolve the problem or to determine whether such claims are proper. In the event that after repeated efforts Server Technology is unable to repair or replace a defective Product, then Buyer’s exclusive remedy and Server Technology’s entire liability in contract, tort, or otherwise shall be the payment by Server Technology of Buyer’s actual damages after mitigation, but shall not exceed the purchase price actually paid by Buyer for the defective Product.

Server Technology shall have no responsibility or liability for any Product, or part thereof, that (a) has had the Serial Number, Model Number, or other identification markings altered, removed or rendered illegible; (b) has been damaged by or subject to improper installation or operation, misuse, accident, neglect and/or has been used in any way other than in strict compliance with Server Technology’s operation and installation manual; (c) has become defective or inoperative due to its integration or assembly with any equipment or products not supplied by Server Technology; (d) has been repaired, modified or otherwise altered by anyone other than Server Technology and/or has been subject to the opening of any sealed cabinet boxes without Server Technology’s prior written consent. If any warranty claim by Buyer falls within any of the foregoing exceptions, Buyer shall pay Server Technology its then current rates and charges for such services.

THE ABOVE WARRANTY IS IN LIEU OF ALL OTHER WARRANTIES, EXPRESS OR IMPLIED, INCLUDING THOSE OF MERCHANTABILITY AND FITNESS FOR A PARTICULAR PURPOSE, ALL OF WHICH ARE EXPRESSLY DISCLAIMED. SERVER SHALL NOT BE LIABLE FOR ANY CONSEQUENTIAL, INCIDENTAL, SPECIAL, OR EXEMPLARY DAMAGES; EVEN OF IT HAS BEEN ADVISED OF THE POSSIBILITY OF SUCH DAMAGES.

For warranty issues, contact the Product Support Department at the number listed above. All repair and return shipments must be approved by Server and must be accompanied by a RMA (Return Merchandise Authorization) number and dated proof of purchase.

Product Registration

Registration is your key to special offers and services reserved for Registered Users.

- Excellent Technical Support Services
- Special Update and Upgrade Programs
- Warranty Protection
- Extended Warranty Service
- New Product Information

Register your products online today!

www.servertech.com

Technical Support

Server Technology understands that there are often questions when installing and/or using a new product. Free Technical Support is provided from 8:30 AM to 5:00 PM, Monday-Friday, Pacific Time.

Server Technology, Inc.

1040 Sandhill Drive

Reno, Nevada 89521 USA

Tel: 775.284.2000

Fax: 775.284.2065

Web: www.servertech.com

Email: support@servertech.com

Return Merchandise Authorization

If you have a unit that is not functioning properly and is in need of technical assistance or repair:

Submit a request for support by phone at the above number, or via the web at

www.servertech.com/support

Be ready to provide:

Company Name

Contact Name, Phone Number, and Email address

Model or Part Number (from the label on the equipment)

Server Technology Serial Number

Version of firmware

Description of problem

1. Technical Support will work to diagnose/resolve the problem remotely, if possible. If the problem cannot be resolved, Technical Support will then issue an RMA# for the return/repair of the equipment in question. RMA#'s are valid for 30 days only from the issue date.
2. Shipping charges for the return of the equipment to Server Technology shall be the responsibility of the customer. For warranty repairs, Server Technology shall assume return shipping charges but for non-warranty repairs, the shipping charges shall be billed.
3. The RMA# shall be placed conspicuously on all shipping documentation, associated correspondence, and the shipping container.
4. Equipment must be returned in proper/original packaging to protect the equipment in transit. The customer shall be financially responsible for any damage/destruction of the equipment due to improper packaging.
5. Equipment shall typically be turned around within 48-72 hours of receipt at Server Technology. Equipment under warranty shall be repaired at no cost. Equipment NOT under warranty shall be repaired at the standard labor rate plus parts. Upon diagnosis of the equipment, the customer shall be notified of estimated charges prior to repair.
6. For non-warranty repairs, return of the equipment will be expedited with the inclusion of a Purchase Order or credit card number for incurred charges



Solutions for the Data Center Equipment Cabinet

Server Technology, Inc.
1040 Sandhill Drive
Reno, NV 89521

+1.800.835.1515 TF
+1.775.284.2000 Tel
+1.775.284.2065 Fax

www.servertech.com
sales@servertech.com

Sentry, Commander, Power Tower XL and Intelligent Power Module are trademarks of Server Technology, Inc.

Other trademarks and trade names may be used in this document to refer to either the entities claiming the marks and names or their products. Server Technology, Inc. disclaims any proprietary interest in trademarks and trade names other than its own.

301-0451-2 Rev. C (081305) © 2004-2005 Server Technology, Inc. All rights reserved.